

# INSTRUCTIONS FOR USING THE MODEL 'J2' FOLBATE LAWN MOWER

## SPARE PARTS

Part No.	Description	No. off	Plate Ref.	Part No.	Description	No. off	Plate Ref.
J.2/1	Wheel, Outer .. .. .	2	1	J.27A	H'dle Br'ket, Bottom (10" size)	1	17
B.2	Pinion, R.H. .. .. .	1	2	B.27	H'dle Br'ket, Bottom (12" size)		
B.3	Pinion, L.H. . . . .	1	3	S.30	Diamond Washer (Handle)	1	20
G.4	Pawl .. .. .	2	4	S.31A	Bolt and Nut, Handle Bracket	1	22
J.1/5A	Sideplate Assembly, R.H. (Bronze Bearing) .. .	1	5	B.29	Handle .. .. .	1	19
J.1/6A	Sideplate Assembly, L.H. (Bronze Bearing) .. .	1	6	*J.30A	Shaft Bracket .. .. .	2	21
B.9	Roller Carrier .. .. .	2	7	B.49	Bolt and Nut, Shaft Bracket	2	27
Q.10	Pin, Split Cotter .. .. .	2	8	*B.32	Roller, Wood .. .. .	1	23
Z.11	Screw, Soleplate Adjustment	4	9	Q.33	Fin, Wood Roller .. .. .	2	24
RM/12	Bolt, Roller Carrier .. .	2	10	*J.1/35	Delivery Plate .. .. .	1	25
*B.15	Soleplate .. .. .	1	11	*J.1/39	Grassbox, without Delivery Plate .. .. .	1	26
*B.15A	Soleplate Assembly .. .	—	—	S.28	Shaft, Handle (10" size) .. .	1	18
SP.16	Screw, Bottom Blade .. .	5	12	B.28	Shaft, Handle (12" size) .. .		
B.17	Screw End, Soleplate .. .	2	13	D.59	Screw, Bronze Bearing Adjust.	2	28
*BA.18B	Cylinder Assembly .. .. .	1	14	J.60	Bearing Bush, Bronze .. .. .	2	29
*GA.23	Bottom Blade .. .. .	1	15	SP.376	Washer, Roller Carrier .. .	2	30
*G.24	Stretcher .. .. .	1	16	L.88	Washer, Soleplate .. .. .	2	31
				H.34A	Spanner .. .. .	1	32
				J.2/106A	Spigot Cover .. .. .	2	33

**IMPORTANT NOTE** :—It is essential when ordering spare parts that the following information is given :—

- a. Model of machine.
- b. Part No. **not** Plate Ref. No.
- c. Description of Part.

N.B.—Where parts are made right hand and left hand, these are determined as the machine is pushed.

OIL OFTEN—USE GOOD O'L. EVERY PART OF THIS MOWER IS MADE IN ENGLAND.

\* When ordering parts marked thus, width of cutting cylinder must be given.

Please quote this reference on all Orders : 11/61

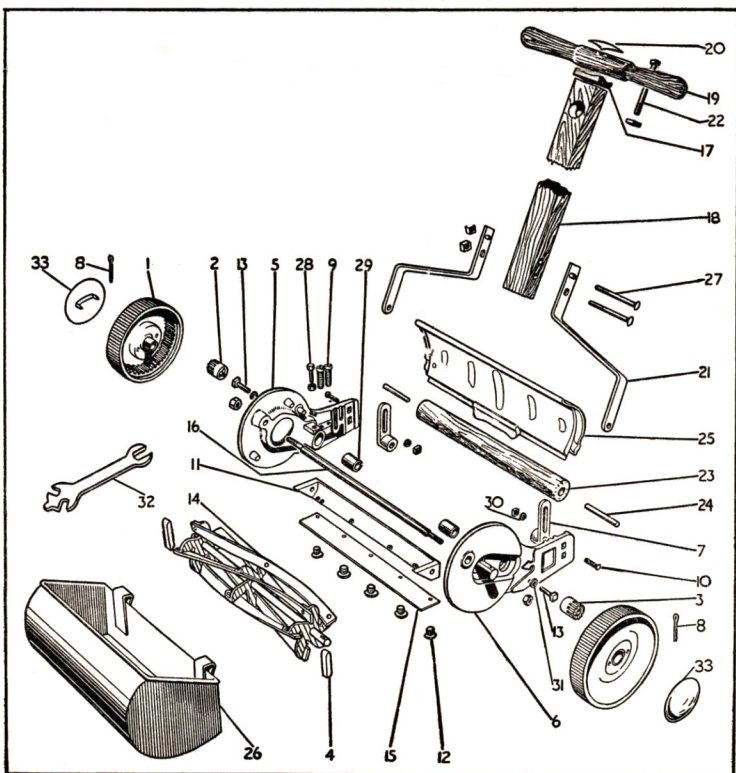

# THE MODEL 'J2' FOLBATE LAWN MOWER

1. Upon unpacking the machine from its carton, examine it carefully to see that it has not been damaged in any way during transit. Spin the cutting cylinder round and see that it is free. You should just hear it touch the bottom blade.

2. **TO ASSEMBLE MACHINE.**—TAKE THE TWO SHAFT BRACKETS (21) AND PLACE OVER LOCATION BOSSES (No. C) ON THE SIDEPLATES OF THE MACHINE, PLACE THE HANDLE SHAFT (18) IN POSITION BETWEEN THEM AND PASS THE TWO BOLTS (27) RIGHT THROUGH BOTH BRACKETS AND SHAFT AND TIGHTEN UP. TAKE HANDLE (19), HANDLE BRACKET (17), DIAMOND WASHER (20) AND BOLT (22), PLACING ALL IN POSITION AT TOP OF HANDLE, TIGHTEN UP TO HOLD ALL RIGID.

3. **OILING.**—(a) To oil the driving wheel bearings there are two holes (one in each wheel), underneath the spigot covers, which can easily be removed by insertion of a screw-driver in recesses provided.

(b) To oil free wheel and small driving pinion, place machine on side and bring oil hole opposite arrow on sideplate. (c) If the cutting edges of the blades are smeared with a well soaked oily rag during use, the labour of mowing is considerably reduced. (d) Although the bearings are of self-lubricating type, it may be necessary after a lengthy period to oil same. An oil hole is provided in each bearing housing on sideplates.

*N.B.*—These are the only places where it is necessary to lubricate.

4. The machine is now ready for use, but must be adjusted for height of user and height of cut.

(a) **Height of User.**—This is done by slackening bolts holding shafts and brackets and moving handle up and down in relation to machine, the brackets being slotted to allow for six inches of vertical movement of handle. When the required position is obtained, tighten up the bolts.

(b) **Height of Cut.**—Place the machine on a flat surface (such as kitchen table), not on the grass itself, loosen the bolts on the brackets supporting the wooden roller, and raise or lower roller until cutting edge of bottom blade is  $\frac{1}{4}$  in. higher than is desired to cut the grass, as the driving wheels sink into the turf slightly. If the grass is long, it is more satisfactory to set for high cut and not strain the machine. The bracket bolt (No. 10) should be in the bottom hole of sideplate for high cut, and it is necessary to transfer this bolt to the top hole to obtain the minimum low cut.

5. **To adjust for keen cutting.**—Every Mower is adjusted before leaving the factory to cut paper  $\frac{1}{250}$  in. thick, and no adjustment should be necessary for some time. If the grass seems bruised and not clipped, reset the bottom blade carefully. The revolving cylinder is fixed and the bottom blade is adjustable. To bring the bottom blade up closer to the cylinder: (a) Release (No. 13) one quarter of a turn on both sides, (b) slacken (No. 9) "A" very slightly, (c) screw down (No. 9) "B" hard, (d) tighten up (No. 13) on both sides. When adjusted correctly the cylinder should spin freely and the machine cut thin brown paper on any part of the blades.

*N.B.*—DO NOT tighten Adjusting Screw (No. 9) "A" without loosening Adjusting Screw (No. 9) "B" or vice versa, otherwise the sideplate or soleplate is rendered liable to breakage.

A remarkably fine sharp cut can be regained on a Mower blunted through hard use at the end of the season by lapping in the blades with fine emery powder and oil. To do this, remove the outer wheels and change the small right-hand pinion over to the left-hand side, replacing the left-hand wheel. Make a paste of fine emery and oil, and smear the edges of the cutting blades with it. Insert the projection on the end of the spanner in the oil hole of the outer wheel and revolve the wheel in the reverse direction, so that the blades run backwards. Perfect contact with the bottom blade at all points can be obtained by this method. Carefully remove all emery prior to re-use, and do not omit to change the pinion back to its correct side, or the machine will not drive.

## TO TAKE UP WEAR AND ADJUST CYLINDER BEARINGS.

6. To take up play between the cylinder spindle and adjusting screw (No. 28) situated on above bearing housing

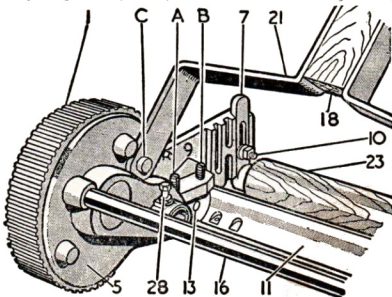

bearing, first slacken locknut on bearing on sideplates. Turn screw in a clockwise direction until there is no play between the cylinder spindle and bearing, and at the same time see that the spindle spins freely. Tighten up locknut.

7. After your Mower has been in use some time, it will, like all new machinery, bed down slightly, so look it over and see if it needs tightening anywhere.

8. Do not run with your Mower, walk steadily at about two miles per hour.

9. Should the grass not be delivered squarely into the grassbox, bend the grass delivery plate until it suits your speed.

10. Cut grass absorbs oil freely, so oil your Mower frequently when in use, and when you have finished mowing for the day, clean it well and wipe all knives with an oily rag.

11. Take off the driving wheels occasionally and clean out the gearing and free wheel in the pinion.

Sole Manufacturers:—

**FOLLOWS & BATE LTD.**  
GORTON, MANCHESTER, 18  
ENGLAND

Printed in England