

SIMPLEES POWER MOWER

INSTRUCTIONS TO THE USER

THE J-P ENGINEERING COMPANY LIMITED

Manufacturers of J-P Super Lawnmowers

MEYNELL ROAD · LEICESTER · ENGLAND

FOREWORD

The J.P. SIMPLEES POWER MOWER is a comparatively light machine yet robust in construction. Its production is fully in keeping with J.P. quality engineering standards, and with proper care and attention will give many years of efficient and reliable service.

There are two models, 14" and 16" which are identical in construction and incorporate the same specification except for variation in the cutting width.

The design is based on a sectional assembly system comprising the Engine Unit, the Cutting Unit, the Rear Roller Assembly and the Front Axle Assembly, each of which can be readily removed without dismantling the main chassis unit.

Instructions and illustrations have been made as simple as possible, but modification in design may affect the specification necessitating some alteration without incurring to us any liability for such alteration to be made on machines already delivered.

Reference in the instructions to left or right hand side of the machine is always understood to be taken when standing in the working position.

J.P. Lawnmowers are fully guaranteed for replacement of any part against failure proved to be due to faulty material or workmanship.

J-P

THE J.P. ENGINEERING COMPANY LIMITED

Makers of Quality Lawnmowers

MEYNELL ROAD . LEICESTER . ENGLAND

Telegrams: "Superlamo" Leicester

Telephone: 67542 (2 lines)

SIMPLES J-P POWER MOWER

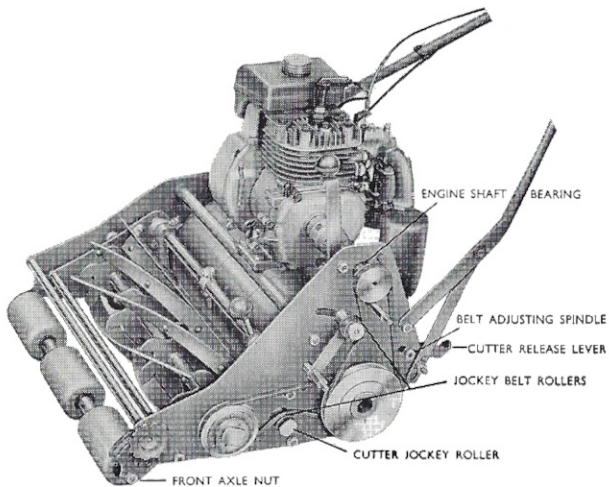

FIG. 1

INSTRUCTIONS

LUBRICATION SECTION A

The following oiling points on the machine should receive frequent attention when in regular use:

- (1) **Front rollers.** Apply oil at the space provided between each roller. To assist the feed of oil, tip the machine on each side. (Medium grade oil every week.)
- (2) **Rotary cutter bearings.** First remove detachable unit. Now place the unit carefully on its side when a rubber plug will be seen in the bearing cover. This should be removed and oil applied to the bearing, afterwards replace. Then turn the opposite end upwards when an oil hole will be seen through one of the large three coupling holes. (Fig. 4). Oil to the bearing should be applied at this point. (Medium grade oil every two weeks.)
- (3) **Front cutter drive bearing** located in the main side frame by first removing the cutter unit. The oil hole will be seen through the large hole in the flange of the cutter coupling. (See Fig. 3.) (Medium grade oil every two weeks.)
- (4) **Rear axle drums and bearings.** Lubricate by first standing the machine upright with the handlebars against a wall. A grease gun lubricator will then be seen each side in the aluminium bearing housings and grease should be applied with the grease gun.
Now slowly revolve each drum when an oil lubricator will be seen projecting from each drum face. Oil should be applied here to lubricate the drive plungers. Grease and oil with medium grade every two months.
- (5) **Engine shaft bearing and jockey belt rollers.** To make these points accessible, first remove the large aluminium transmission cover. Then apply oil to the engine shaft bearing at the back of the small vee pulley (tip the machine on its side to assist the flow of oil). Then apply oil through the oil holes in the side flanges of the roller pins. (Medium grade oil, every two months.)
When oiling the transmission, care should be taken to see that no oil or grease finds its way on to the vee belt surfaces as this might cause temporary belt slip.
- (6) **Lever linkage points.** Oil with medium grade oil every month.

SIMPLES **J-P** POWER MOWER

- (7) **Rear roller assembly.** The centre section gear case chamber of the rear roller is an assembly in two halves and contains the epicyclic speed up gears which run in an oil bath inside the gear case chamber. It is only necessary to change the oil *annually* and replenish with a charge of fresh oil. (IMPORTANT—a quantity not more than a third of a pint.) Access to the oiling point is made by first unscrewing the hexagon brass cover screw seen in the recess of the centre section rear roller. (Ref. fig. 3) Care should be taken to clean away all dirt and grit before removing the hexagon screw.

Proceed as follows:

First remove the cutter unit and tip the machine backwards with the handlebars resting on the ground. Then turn the roller until the hexagon plug is in the vertical position, to enable it to be unscrewed and removed with the box spanner provided. Now turn the roller with the oiling point to the ground to allow the oil to be drained away.

When the chamber is empty, the roller should again be turned until the oiling point is in the vertical position, to make it accessible for a fresh charge of oil to be applied. Then replace the plug and screw up tight.

The type of oil to be used for the rear roller should be Castrol Hypoy S.E.A. 90EP or similar viscosity. *Do not use thin oil.*

STARTING PREPARATION SECTION B

- (1) The machine is carefully set for cutting adjustment before despatch and to adjust the shear blade to the rotary cutter move the red headed adjusting lever of the Cutter Unit in the direction toward the rear roller as far as it will go.

It should be explained that the machine is fitted with a cutter setting stop, the feature of which is a great assistance insofar that after the mowing is completed, the cutting contact of the shear blade and rotary cutter can be released by moving the round headed lever forward away from the rear roller; subsequently when the machine is to be used again, it is only necessary to move the round headed adjusting lever as far as it will go up to the setting stop, which will bring the cutter setting in the pre-adjusted position.

- (2) **Setting for Height of Cut**

Adjust the front rollers by positioning in the traverse slot of the adjusting brackets after unscrewing the two handwheels; tighten up securely onto the adjusting brackets after obtaining the setting required. (Do not set too low, particularly for the first cuts of the season or at such times when the lawn may be in a soft condition.) Ref. fig. 2.

- (3) **Fixing the Grassbox**

To fix the grassbox into position, first insert the two metal wings between the chassis side frame. The box can then be lowered, with the bottom slot of the wing engaging in each of the unit supporting pages, and the upper slot resting on the front cross tie bar.

When emptying and replacing the grassbox, first disengage the rotary cutter drive for safety, by moving upwards with the foot the cutter release lever (fig. 1.).

Always keep fingers away from the Rotary Cutter at any time the engine is running.

- (4) **Engine Important: Check for Oil**

Do not overcharge the engine crank case with oil. The quantity of oil should come up to the lower half of the inlet orifice with the machine standing in its normal working position, not tilted backwards.

- (5) **To Start Engine**

Please refer to engine instructions.

SIMPLES **J-P** POWER MOWER

(6) To Commence Cutting

With the starting preparation completed and adjustments made, the machine can now be put into motion by first engaging the drive of the cutters by moving the black knobbed lever as far as it will go in the forward position. (See fig. 2.)

Now gently raise the drive clutch lever situated on the right handlebar and retain this in the raised position to keep the machine in motion.

Simultaneously, the engine carburettor control lever should be adjusted to give the desired engine speed.

REMOVAL OF SUB ASSEMBLIES SECTION C

Special attention has been given in the design of the machine to the importance of easy service and maintenance. With this in view, the construction has been based on a system of sectional assembly, comprising the Power Unit, Cutter Unit, Rear Roller Unit and the Front Axle Unit, each of which can be readily removed without dismantling the main frame chassis assembly.

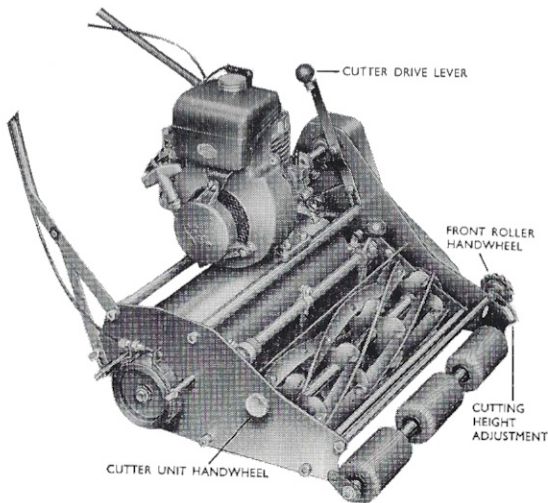

FIG. 2

(1) To Remove the Power Unit

The Power Unit is secured direct on the two cross tie bars. The three hexagon head attaching screws, two at the front and one at the rear should be unscrewed and taken out.

The Engine can now be moved endwise along the tie bars, clear of the coupling. To re-assemble, the reverse procedure should be adopted, taking care to see that all nuts are tight and secure.

SIMPLEES J-P POWER MOWER

(2) To Remove the Cutter Unit

First unscrew the handwheel of the retaining pin for about half an inch (see fig. 2). The Cutter Unit can then be moved by sliding along the tie bars as far as it will go until the cutter nut and coupling (ref. fig. 3) is clear of the three pins in the driving coupling. The Unit can then be taken out of the chassis by lifting in a swinging motion from the back. The Cutter Unit is replaced by placing the front slots of the Cutter Unit frames on the two front retaining pins seen projecting from inside of each chassis frame. The Unit should then be carefully lowered in a downward swinging motion until the rear slots of the cutter unit frames rest on the cross tie bar and can then be moved in a lateral direction away from the retaining pin until the three holes of the cutter nut and coupling are in full engagement with the three pins of the driving coupling. Finally screw up the handwheel with the retaining pin engaging the hole in the side frame on the opposite side.

(3) To Remove the Rear Roller Assembly

First remove the large transmission cover by unscrewing and taking off the two retaining nuts and remove both driving belts. Unscrew the two retaining nuts and take off the band clutch cover on the opposite side. Both the large double Vee Pulley and also the clutch drum on the rear axle should be removed by first unscrewing and taking out the two hexagon retaining bolts. The four hexagon head bolts which hold the aluminium bearing housings should be unscrewed and removed.

The complete axle can then be taken from the chassis by lowering the projecting ends of the shafts and passing down the slots in the side frame.

(4) To Remove Front Roller Assembly

Unscrew and take off the two front handwheels (ref. fig. 2). Then unscrew and take off the one axle nut on the traverse slotted adjuster on the transmission side (ref. fig. 1). The slotted adjuster on the transmission side can then be withdrawn endwise from its engagement with the rear pin and front axle. The axle complete with rollers and one slotted adjuster still attached can be taken endwise clear of the studs away from the chassis.

MAINTENANCE ADJUSTMENTS SECTION D

Cutter Setting Stop

Special Note: On any future occasion of the cutters being reground, or the machine dismantled, it is important to see that the cutter setting stop is re-adjusted and the procedure should be as follows:

- (1) First unscrew the locking nut of the setting stop screw a couple of turns to release the stop and make it free on the tube. (Ref. fig. 4.)
- (2) Now set the bottom shear blade parallel to the rotary cutter. (Please refer to the instructions, reference Parallelism of Cutters.)
- (3) Adjust the bottom shear blade to a **LIGHT AUDIBLE CONTACT** with the rotary cutter by moving the round headed lever in the direction of the rear roller (see fig. 4).
- (4) With the cutters adjusted to a **LIGHT AUDIBLE CONTACT**, the cutter setting stop should be rotated and positioned so that the bottom end of the stop contacts up against the back of the grass shield. The lock nut and screw should then be tightened securely in position. A light audible contact between the rotary cutter and the shear blade will give the best cutting results. Too harsh a contact will only cause unnecessary wear.

SIMPLEES J-P POWER MOWER

Parallelism of Cutters

The cutter unit is set and inspected before despatch to cut equally along the whole length of the rotary cutter when the contact adjustment with the bottom shear blade is made, and no attention to correct any mis-alignment should be necessary unless the machine has been dismantled or subjected to excessive shock or through fouling an obstruction.

Out of alignment of the bottom shear blade with the rotary cutter can be corrected by the following adjustment:

First remove the cutter unit from the chassis, on the right hand side of the unit will be seen a brass headed adjuster which is connected to the top tie bar by a flat link. (See fig. 4.)

The tie bar nut should be unscrewed a couple of turns and the brass adjuster should then be turned; this action will higher or lower the knife frame to which is attached the shear blade, and will enable the bottom shear blade to be adjusted into parallel relationship with the rotary cutter.

To ensure that the adjustment has been made correctly, the setting should be tested with a strip of ordinary brown paper by cutting from end to end on each blade of the rotary cutter. The cutting test should be made with the shear blade adjusted to a light audible contact with the rotary cutter. (Ref. Cutter Setting Stop.)

After adjustment, tighten up the tie bar locknut securely.

Tension of the Shear Blade Adjuster

The tension of the red headed lever adjuster for bringing the blades into contact can be adjusted by the screws which secure the two knife frame strips in position. (See fig. 4.)

Under the holding screws is a compression washer which permits tension adjustment to be made. The two holding screws should always be reasonably tight to give a moveable tension to the eccentric adjustment which is operated by the lever. The correct tension adjustment is important as it ensures against any disturbance of the cutter setting through vibration.

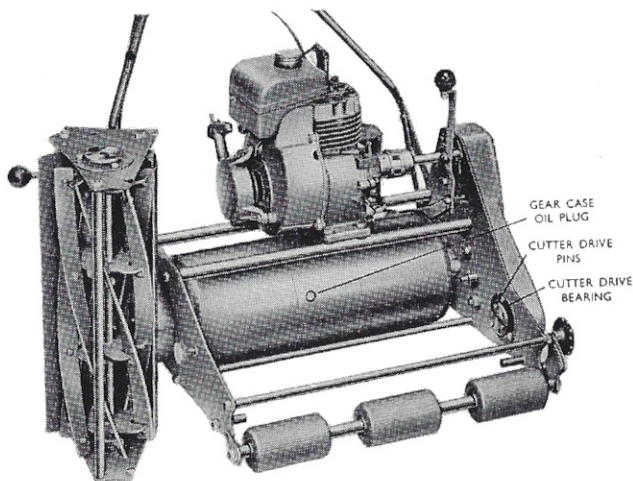

FIG. 3

SIMPLEES J-P POWER MOWER

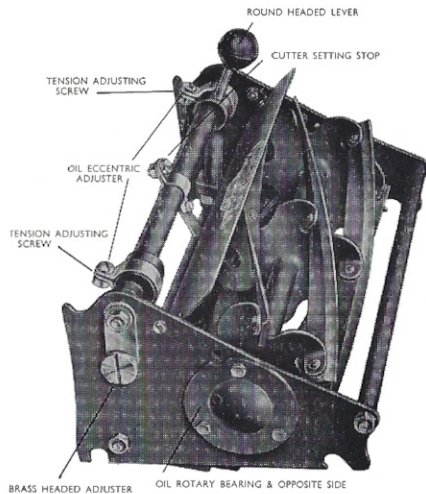

FIG. 4

Cleaning and Removing the Rotary Cutter Unit

Upon completion of the mowing, clean off all the clinging grass and dirt and store in a dry tool shed. NEVER USE WATER.

To clean the machine thoroughly, the cutter unit can easily be detached from the chassis by unscrewing the knurled handwheel seen on the right hand side frame. The cutter unit can be then moved over to the left as far as it will go, clear of the engaging drive coupling and then lifted clear out from the chassis.

Care should be exercised when cleaning the unit to *keep the fingers away from the bottom shear blade and the rotary cutter blades*. Handle the unit carefully and do not bump or subject it to shock otherwise the parallel cutting adjustment may be disturbed.

Vee Belt Adjustment

The Vee drive belts should be kept reasonably tight, sufficient to impart drive to the machine and rotary cutter.

Adjustment is provided as shown in fig. 1.

The tension of the cutter drive belt is adjusted by means of highering or lowering the spindle on which is mounted the jockey roller. (Fig. 1.)

The rear axle belt is adjusted by the adjusting spindle which engages the bottom horizontal lever. (Fig. 1.)

To tighten the belt the spindle should be slightly moved in an outward direction away from the machine.

Special Note: Adjustment to the belts should not very often be necessary, but when it does arise, it is important not to adjust the belts too tight as this will cause unnecessary stretch without improving driving efficiency.

SIMPLEES J-P POWER MOWER

Clutch Adjustment (Rear Axle Driving Clutch)

The main driving clutch is mounted on the end of the rear axle spindle on the right hand side. The clutch assembly comprises a cast iron drum inner member which works with, and is encircled by, a steel brake band lined with Ferodo, which operates dry (no lubrication of any kind is required).

Adjustment is provided for tightening the band on the inner member should this be necessary through wear. First remove the aluminium clutch cover by unscrewing and taking off the two hexagon-headed screws seen on the outside of the cover. It will then be seen that the Bowden cable connects the two ends of the protruding lugs of the steel band, passing through the knurled adjusting screw.

To take up any slackness which might be causing lack of drive, the lock nut on the adjuster screw situated between the two clutch band lugs should be unscrewed for three or four turns; the knurled adjuster screw should then be turned in an anti-clockwise direction, at the same time retaining the nut situated between the knurled head of the screw with a spanner. This will close the band and take up any wear or slackness.

Adjustment should be made so as to give freedom of clutch movement, when the clutch operating lever on the handle-bar is in the free position. See that the lock nuts are tight and secure after making adjustment. Replace clutch covers and screws.

AFTER SERVICE AND INSTRUCTIONS FOR ORDERING SPARE PARTS

- (1) We have available a first class overhaul and repair Service Department, fully equipped with modern facilities. Consult your Dealer with regard to your requirements, or, in case of difficulty, contact us direct.
Always see that the machine and cutters returned for overhaul and re-grinding are properly packed and labelled with the name and address of the sender securely attached. On request, we will despatch a crate for the return of your machine for works overhaul and service attention.

- (2) When ordering spare parts, always quote the serial number of the machine or detachable cutter unit, which will be found on a plate attached to the side frame in each instance, and these numbers should always be quoted in correspondence.

When referring to the parts list, please note that in instances where the letter F or X prefaces the part number, this indicates the size of the machine. F for 14" and X for 16". In such instances where neither the letter F or X prefaces the part number, this indicates that the part in question is common to both sizes.

- (3) All machines and component parts must be consigned to us, carriage paid, addressed to the Service Department; goods returned by rail are consigned Carriage Paid. Old and worn out parts sent as patterns which we consider are obsolete and of no further use are not returned unless we are specially requested to do so at the time they are sent to us.
- (4) If required, we are prepared to submit an estimate before proceeding with any repairs.
- (5) Estimates must be treated as approximate only. We reserve the right to include additional parts should they be found necessary on further examination to make the repair a satisfactory job.

SIMPLES J-P POWER MOWER

SPARE PARTS FOR SIMPLES MODELS, 14" AND 16"

<i>Part No.</i>	<i>Description</i>
Group 1 - 0	
G1-8/I	Unit Bearing Stud
G1-17/I	Handlebar Grip
19-9-18	Control Lever Clutch
17B1-19	Clutch Cable
Group 2 - 0	
FD2-1	Drum Complete
D2-1D	Oiler
19-2-2	Plunger Pawl
19-2-3	Taper Pin
19-2-4	Plunger Spring, 14"
X19-2-4	Plunger Spring, 16"
19-2-7A	Dowel—Half Gear Case
D2-7B	Planet Half Gear Case
FD2-7C/D	Planet Gear Case Tube 14"
XD2-7C/D	Planet Gear Case Tube 16"
D2-8B	Annular Gear Case
FD2-8C/D	Annular Gear Case Tube 14"
XD2-8C/D	Annular Gear Case Tube 16"
D2-9	Gear Case Screw
D2-10	Planet Gear Axle
19-2-11	Planet Gear Axle Pin
19-2-11A	Planet Gear Axle Washer
19-2-11B	Planet Axle Split Pin
D2-12	Planet Gear
D2-13	Annular Gear
19-2-14P	Annular Gear—Taper Pin
FD2-16	Annular Gear Shaft, 14"
XD2-16	Annular Gear Shaft, 16"
B2-16S	Setscrew
D2-17	Pinion
19-2-17A	Pinion Taper Pin
FD2-18	Pinion Shaft, 14"
XD2-18	Pinion Shaft, 16"
D2-19	Pulley Sleeve
D2-20	Rear Axle Pulley
PE19-2-22	Brake Drum
D2-23	Brake Band Complete
PE19-2-23B	Brake Lining Ferodo
PE19-2-23C	Rivet
D2-30 ST	Vee Belt, M24 (STANDARD)
D2-30 SU	Vee Belt, M26 (SPORTS GREEN ONLY)
D2-30A	Belt Guide

SIMPLEES J-P POWER MOWER

<i>Part No.</i>	<i>Description</i>
B2-31	Bearing Housing L.H.
B2-31A	Circlip
B2-32	Bearing Housing R.H.
B2-33	Setscrew
D2-38	Freewheel Sleeve
D2-39	Cutter Drive Pulley Complete
D2-41	Cutter Coupling
D2-42	Rubber Friction Disc
B2-43	Oiler Plug
B2-43W	Fibre Washer
B2-45	Grease Nipple
 Group 3-0	
FG3-1	Rotary Cutter Complete, 14"
XD3-1	Rotary Cutter Complete, 16"
D3-5	Female Clutch Coupling
G3-8	Cutter Ball Race
G3-19/1	Domed Cover Cap
D3-20	Drive Side Cover Cap
G3-21	Bearing Housing
D3-5A	Rubber
 Group 4-0	
FG4-1/1	Shear Blade, 14"
XD4-1	Shear Blade, 16"
G4-2	Shear Blade Screw
FG4-3	Shear Blade Carrier, 14"
XD4-3	Shear Blade Carrier, 16"
G4-8	Adjusting Handle
G4-9	Adjusting Knob
H4-12A	Cutter Setting Stop Complete, Lower
H4-12B	Cutter Setting Stop Complete, Upper
FG4-16	Deflector Plate Assembly Complete, 14"
XD4-16	Deflector Plate Assembly Complete, 16"
 Group 5-0	
G5-1	Front Roller
FD5-2	Front Axle Shaft, 14"
XD5-2	Front Axle Shaft, 16"
FD5-3	Centre Spacer, 14"
XD5-3	Centre Spacer, 16"
G5-4	End Spacer
G5-5W	Front Axle Washer
G5-6	Adjuster Arm Complete
M5-4/1	Adjuster Arm Complete
G5-9	Handwheel

SIMPLEES J-P POWER MOWER

<i>Part No.</i>	<i>Description</i>
Group 6 - 0	
FD6-0	Grassbox, 14"
XD6-0	Grassbox, 16"
Group 7 - 0	
D7-1	Jockey Pin—Cutter Drive
D7-2	Jockey Pin Spacer
D7-3	Jockey Pin—Main Drive
D7-4	Jockey Pin—Main Drive—End Piece
A9-10	Jockey Pulley Bush
D9-11	Jockey Pulley
G2-13W	Jockey Pin—Main Drive—Spacer
D7-5	Pivot Pin—Radius Arm
D7-6	Operating Lever Complete
D7-7	Radius Arm—Jockey Pin
A9-32	Pivot Pin—Operation Lever
A9-34	Trip Lever
A9-35	Spring—Trip Lever
A9-36	Adjusting Pin
D7-8	Unit Retaining Pin
B7-16	Adjusting Screw Cable
19-7-38	Rubber Clips

