

INSTRUCTIONS FOR USING "QUALCAST" MODEL 'B1' LAWN MOWER

1. Upon unpacking the machine from its carton, examine it carefully to see that it has not been damaged in any way during transit. Spin the cutting cylinder round and see that it is free. You should just hear it touch the bottom blade.

2. TO ASSEMBLE MACHINE.

First remove split pins from each sideplate handle arm location bosses (No. C), spring handle into position taking care to replace split pins before use.

3. OILING.

(a) To oil the driving wheel bearings there are two holes (one in each wheel) underneath the spigot covers which can easily be removed by insertion of a screw-driver in recesses provided. (b) To oil free wheel and small drive pinion, place machine on side and bring oil hole opposite arrow on side plate. (c) If the cutting edges of the blades are smeared with a well soaked oily rag during use, the labour of mowing is considerably reduced. (d) Although the bearings are of self-lubricating type, it may be necessary, after a lengthy period, to oil same. An oil hole is provided in each bearing housing on side plates.

N.B.—These are the only places where it is necessary to lubricate.

4. The machine is now ready for use, but must be adjusted for height of user and height of cut.

(a) **Height of User.**—The handle may be adjusted to a convenient height for the user by means of the adjusting bolts (No. 32).

(b) **Height of Cut.**—Place the machine on a flat surface (such as kitchen table) not on the grass itself, loosen the bolts on the brackets supporting the wooden roller and raise or lower roller until cutting edge of bottom blade is $\frac{1}{4}$ in. higher than is desired to cut the grass, as the driving wheels sink into the turf slightly. Where two sets of holes are provided in the sideplate the minimum height of cut is obtained by placing bolts in top set of holes. If the grass is long, it is more satisfactory to set for high cut and not strain the machine. The bracket bolt No. 11 should be in the bottom hole of sideplate for high cut, and it is necessary to transfer this bolt to the top hole to obtain the minimum low cut.

5. **To adjust for keen cutting.**—Every Mower is adjusted before leaving the factory to cut paper $\frac{1}{250}$ in. thick, and no adjustment should be necessary for some time. If the grass seems bruised and not clipped, reset the bottom blade carefully. The revolving cylinder is fixed and the bottom blade is adjustable. To bring the bottom blade up closer to the cylinder: (a) Release (No. 14) one quarter of a turn on both sides, (b) Slack (No. 10) "A" very slightly, (c) Screw down (No. 10) "B" hard, (d) Tighten up (No. 14) on both sides. When adjusted correctly the cylinder should spin freely and the machine cut thin brown paper on any part of the blades.

N.B.—DO NOT tighten Adjusting Screw (No. 10) "A" without loosening Adjusting Screw (No. 10) "B" or vice versa, otherwise the Side Plate or Sole Plate is rendered liable to breakage.

A remarkably fine sharp cut can be regained on a Mower blunted through hard use at the end of the season by lapping in the blades with 90 emery powder and oil. To do this, remove the outer wheels and change the small right-hand pinion over to the left hand side, replacing the left-hand wheel. Make a paste of 90 emery and oil, and smear the edges of the cutting blades with it. Insert the projection on the end of the spanner in the oil hole of the outer wheel and revolve the wheel in the reverse direction, so that the blades run backwards. Perfect contact with the bottom blade at all points can be obtained by this method. Carefully remove all emery prior to re-use, and do not omit to change the pinion back to its correct side, or the machine will not drive.

TO TAKE UP WEAR AND ADJUST CYLINDER BEARING.

6. To take up play between the cylinder spindle and bearing, first slacken locknut on bearing adjusting screw (No. 28) situated on above bearing housing on side plates.

Turn screw in a clockwise direction until there is no play between the cylinder spindle and bearing, and at the same time see that the spindle spins freely. Tighten up locknut.

7. After your Mower has been in use some time, it will, like all new machinery, bed down slightly, so look it over and see if it needs tightening anywhere.

8. Do not run with your Mower, walk steadily at about two miles per hour.

9. Should the grass not be delivered squarely into the grassbox, bend the grass delivery plate until it suits your speed.

10. Cut grass absorbs oil freely, so oil your Mower frequently when in use, and when you have finished mowing for the day, clean it well and wipe all knives with an oily rag.

11. Take off the driving wheels occasionally and clean out the gearing and free-wheel in the pinion.

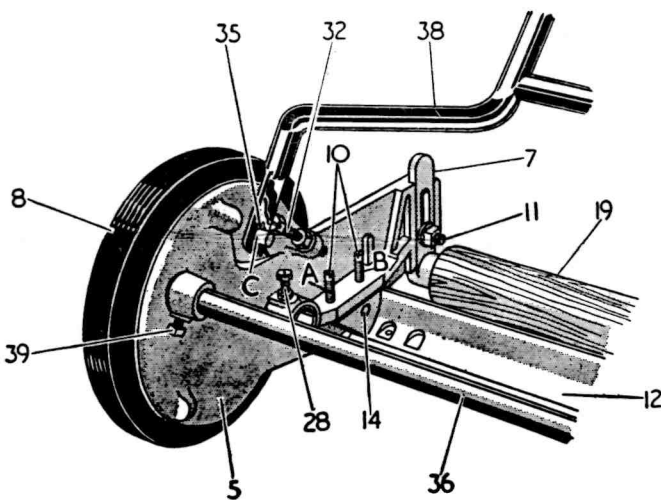

INSIST ON "QUALCAST" SPARES.

SOLE MANUFACTURERS: QUALCAST LTD. DERBY, ENGLAND.

THE "QUALCAST" MODEL 'B.1' LAWN MOWER

SPARE PARTS

Part No.	Description.	No. off	Plate Ref.	Part No.	Description	No. off	Plate Ref.
B.1A	Wheel, Outer	2	1	B.34	Spanner	1	19
E.2	Pinion, R.H.	1	2	*B.35	Delivery Plate	1	20
E.3	Pinion, L.H.	1	3	*B.35A	Delivery Plate Assembly	1	—
G.4	Pawl	2	4	*B.36	Delivery Bar	1	21
B.5B	Side Plate Assembly, R.H. (Bronze Bearing)	1	5	*E.1/39	Grassbox, without Delivery Plate	1	22
B.6B	Side Plate Assembly, L.H. (Bronze Bearing)	1	6	B.42	Screw, Delivery Plate	2	23
B.9	Roller Carrier	2	7	B.58	Grips, Handle	2	24
A.10A	Tyre	2	8	D.59	Screw, Bronze Bearing Ad- justing	2	25
Q.10	Pin, Split Cotter	2	9	J.60	Bearing Bush, Bronze	2	26
Z.11	Screw, Sole Plate Adjustment	4	10	HD.83	Bolt and Nut, Handle Ad- justing	2	27
J.12	Bolt, Roller Carrier	2	11	E.88	Washer, Roller Carrier	2	28
*B.15	Sole Plate	1	12	L.88	Washer, Sole Plate	2	29
*B.15A	Sole Plate Assembly	—	—	K.91	Pin, Split Cotter (Handle Arm Lug)	2	30
E.16	Screw, Bottom Blade	5	13	*E.1/103	Tube, Front	1	31
B.17	Screw End, Sole Plate	2	14	J2/106A	Spigot Cover Assembly	2	32
*B.18A	Cylinder Assembly	1	15	*B.316A	Arm, Handle	1	33
*GA.23	Bottom Blade	1	16	B.329	Screw, Front Tube	2	34
*B.32	Roller, Wood	1	17				
Q.33	Pin, Wood Roller	2	18				

IMPORTANT NOTE.—In ordering parts which are made right and left hand, please specify which hand is needed as you push the machine, and always give the number and name of part, with letter which is marked on part.

OIL OFTEN AND USE GOOD OIL

EVERY PART OF THIS MOWER IS MADE IN ENGLAND

* WHEN ORDERING PARTS MARKED THUS, WIDTH OF CUTTING CYLINDER MUST BE GIVEN

Please quote 1's reference on all orders 2/58

