

SUFFOLK

SUPER COLT

motor mower

FOUR STROKE ENGINE

OPERATING & MAINTENANCE
MANUAL

RS. 4895 / 7 / 72

Read this before using the Mower.

ALWAYS REMOVE STONES, ETC. FROM THE LAWN BEFORE MOWING.

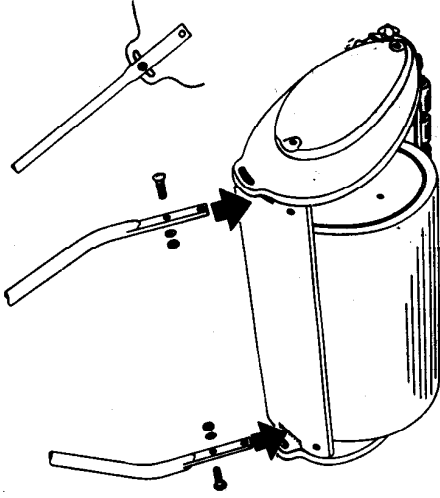

Fig. 1

PREPARING THE MOWER FOR USE

Handle

Fit the lower ends of the handle into the two slots at the rear of the engine platform so that they fit onto the small projections on the inside of the side plates. Then pass the bolts through the slots in the sideplates and through the holes in the handle. The nuts should always be on the inside.

Before tightening, set the handle at the required height.

Control Levers

These should be fitted to the handle by the straps and screws, in convenient positions, close to the handle grips. The throttle control lever is normally fitted at the right hand side, and the clutch lever at the left. The cables should be arranged in smooth curves, and fixed by the cable clips, as illustrated in Fig. 2.

Petrol Tank

This should be fitted over the handle and pressed down so that it wedges firmly in position, with the filler cap at the top. The petrol pipe should be pushed firmly over the inlet pipe on the carburetter, so that petrol can flow from the tank to the carburetter, when petrol tap is turned on. See Fig. 2

Engine Oil

Before starting the engine, remove the filler plug at the front of the engine, and put half a pint of oil in the crankcase. The engine nameplate recommends the correct grade of oil.

Do not over-fill.

Replace the filler plug firmly, together with the dipstick. Afterwards the oil level should be checked on the dipstick every time before use, and more oil added when necessary, to bring the level up to the mark on the dipstick. Dipstick readings should always be taken with the mower on level ground, and the Dipstick should be replaced firmly after use.

(See notes A, B, C, D, regarding oil changes, etc.).

To change the engine oil, remove the drain plug at the rear of the engine, and allow the old oil to run out. This should be done immediately after use, so that the hot oil drains freely. Tilt the mower slightly to ensure complete drainage. When empty replace the plug firmly, and add clean oil as described above.

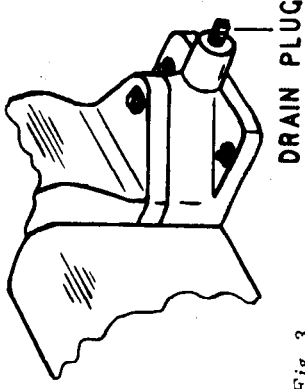

Fig. 3

Petrol (DO NOT MIX WITH THE PETROL)

Unscrew the filler cap and remove anti-rust paper. Rinse tank with petrol before filling for the first time.

Fill the petrol tank with CLEAN petrol, preferably of a cheaper grade (Three Star). The tank holds approximately 1½ pints, which is enough for about 1½ hours' work.

Always replace the cap on the petrol tank.

Warning.

It is dangerous to fill the petrol tank while the engine is running.

Height of Cut (DO NOT ADJUST WHILE ENGINE IS RUNNING).

To regulate the height of cut, loosen the finger wheels holding the roller brackets, and with the mower on a flat surface, set the brackets to the desired height, then tighten the finger wheels with the spanner supplied.

It is important that the brackets be adjusted equally.

Starting the Engine

Warning: - Never race the engine when new.

Turn the petrol on by pulling the tap button out gently, and open the throttle control lever.

Partly close the choke lever to a position about 45 degrees to the vertical.

(Under cold conditions, the choke should be completely closed by turning the lever to a horizontal position, but this is not often necessary.)

(Under hot conditions it may be easier to start with the choke wide open, that is, with the lever vertical.)

Lever down - choke open.

Lever sideways - choke closed.

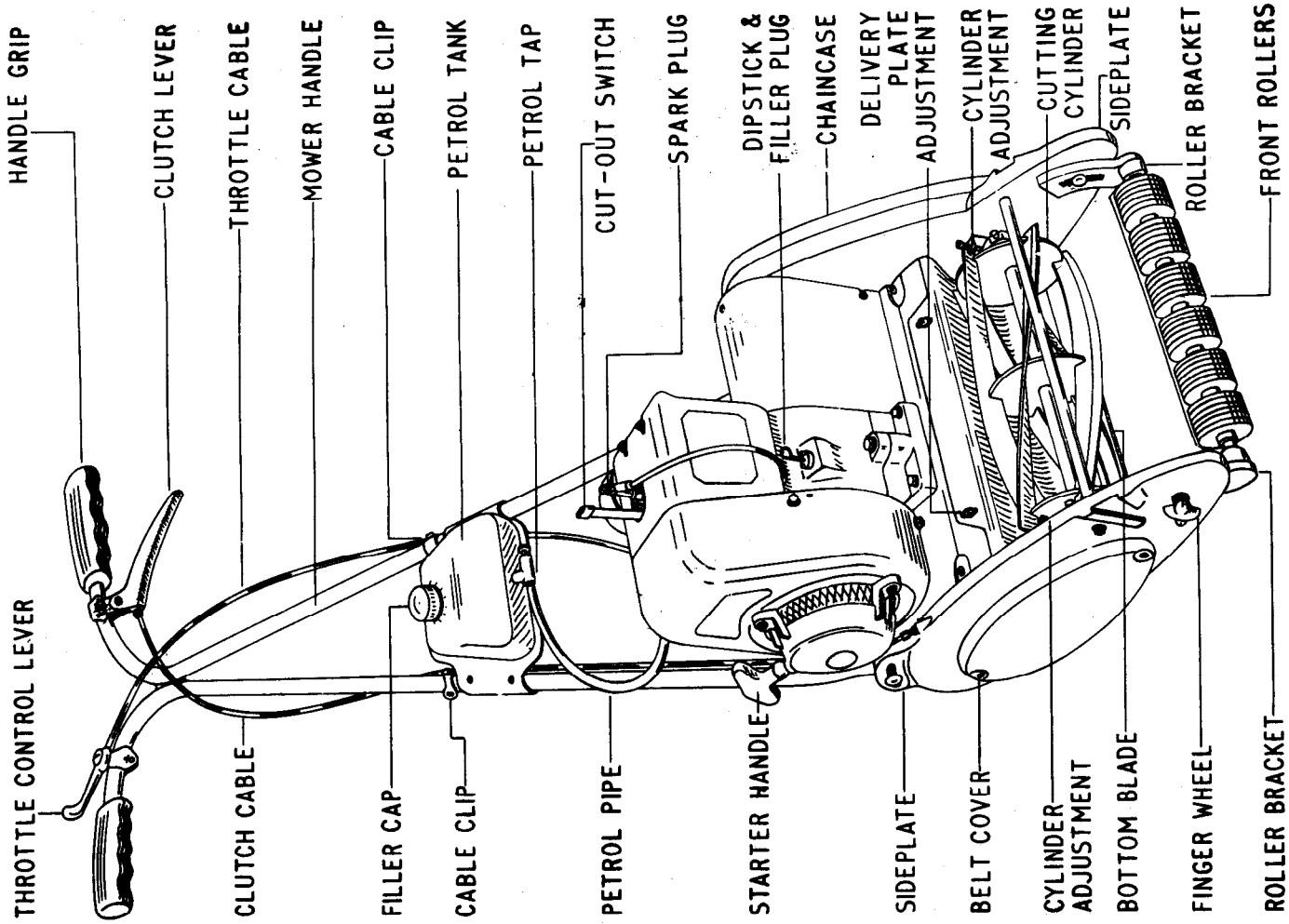

Fig. 2

TICKLER

CARBURETTER

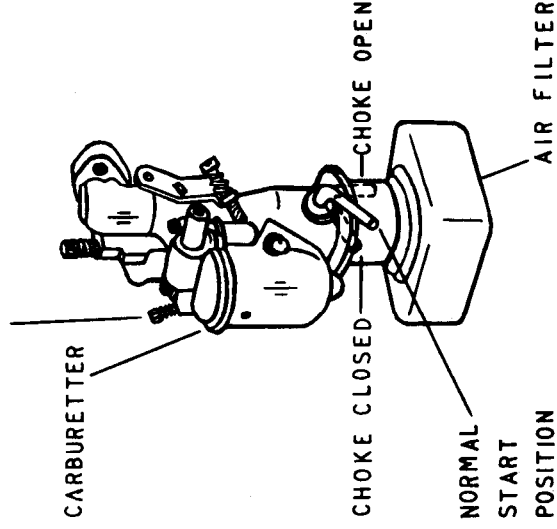

Fig. 4

Press the tickler on the top of the carburettor until petrol just begins to overflow through the small hole.

Holding the mower steady, grasp the starter handle firmly, and pull smartly, until about two feet of rope is showing. Maintain your grip on the handle, but let the rope recoil gently. Do not release your grip on the starter handle until the rope has recoiled. To allow the rope to fly back could damage the spring.

After one or two pulls the engine should start, and as it warms up the choke should be opened, and the throttle lever closed, until the engine is ticking over quietly.

Stopping the engine

To stop the engine, press the cut-out switch on to the spark plug and hold it there until the engine stops. If the engine is to be stopped for any length of time, turn the petrol off.

Fitting the Grassbox

Locate the brackets on the box on the slots in the sideplates.

Using the Mower

When the throttle is opened, the engine will speed up and drive the cutting cylinder, but the mower will not move under power until the rear roller clutch is engaged.

With the clutch disengaged, it is easy to mow awkward corners, pushing the mower by hand.

For fully propelled operating, pull back the clutch lever, and the mower will move forward under its own power.

The speed of the mower can be adjusted to a convenient walking pace by opening or closing the throttle control lever.

When turning at the end of each strip, simply release the clutch lever, and turn the mower as required.

Stopping

To stop the mower moving, release the clutch lever.

To stop the cutting cylinder rotating, close the throttle.

ROUTINE ADJUSTMENTS AND MAINTENANCE.

NEVER MAKE ADJUSTMENTS WITH THE ENGINE RUNNING.

Cutting Cylinder

When correctly adjusted, the cylinder blades should lightly and evenly touch the bottom blade. Adjusting screws are provided at each end to raise or lower the cylinder. Turning the screws clockwise will bring the cylinder blades close to the bottom blade. After adjusting the cylinder, always check the chain tension, see page 7.

Warning

Take care when rotating the cutting cylinder by hand, as the blades are very sharp.

Delivery Plate

If grass cuttings are not being thrown properly into the grassbox, the angle of the delivery plate may be altered by loosening the two screws, sliding the delivery plate forward or backward a little as necessary, then tightening the screws again. See Fig. 2.

Clutch Adjustment

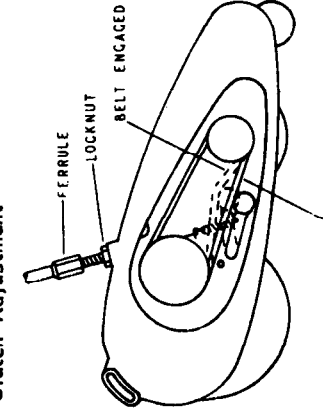

Oil BELT DISENGAGED Fig. 5

The following points should be oiled with light machine oil each time before use:- The cutting cylinder bearings, through the spring cap lubricators; the rear roller, through the small hole at the right hand side, and the front rollers at each end and between the rollers. The left hand end of the rear roller should be oiled with the machine tilted forward on the front roller. See Fig. 7.

WARNING Do not oil the centrifugal clutch, or the vee belt drive.

GREASE

After every 15 hours' use (say once a quarter) remove the chaincase and grease the chain.

Air Filter

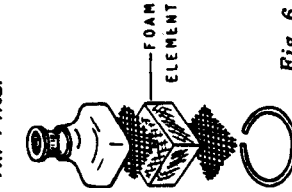

After every 30 hours' use or more often if conditions are extra dusty, pull off the air filter and take out the foam element.

Wash the element in petrol, squeeze out, and allow to dry. Then replace carefully.

Replace the element after 100 hours' use.

Ignition Details

Spark Plug Gap .020 ins. to .025 ins.

Fig. 6

Cleaning and Checking Magneto Points

Remove inspection cover on flywheel and turn engine until points are visible through the aperture.

Turn flywheel slowly until points are at the widest gap and check with a feeler gauge to the recommended gap of .018 - .020. Clean if necessary.

For adjustment loosen the large locking screw and turn the small screw which opens or closes the points. After adjustment retighten the large screw and replace the inspection cover

Bolts

Check bolts and nuts for tightness, after the first 5 hours' use, and re-check after every 30 hours' use.

FOR BEST RESULTS FOLLOW THIS SIMPLE ROUTINE

- A. Before use, each time
Oil mower, check petrol and engine oil levels.
Change engine oil and check bolts and nuts.
Remove chaincase and grease chain.
- B. After first 5 hours
Change engine oil, check bolts and nuts, grease chain and clean air filter.
- C. After every 15 hours
once a year preferably before winter storage)
- D. After every 30 hours (say

Storage: The mower should be kept in a dry, ventilated place.

For Winter Storage

Grease the cutting surfaces and change the engine oil as previously described. Remove the spark plug, insert a teaspoon of engine oil in the hole, and turn the engine over a few times by means of the recoil starter, then replace the spark plug.

General

If mower is damaged or faulty when received, inform your supplier at once.

CARBURETTER ADJUSTMENT

This is not often necessary and should not be attempted unless it is necessary.

1. If tick-over is too slow or too fast, this can be corrected by turning the Throttle Stop Screw as required (clockwise to increase speed, and vice versa) with the throttle control lever in the closed position. (See Item 4 in diagram on page 19).
2. Slow running mixture control. Tick-over and starting may be improved by turning the Air Regulating Screw (Item 1 on page 19) a little one way or the other, taking care not to force the screw into its seating. The usual position for this screw is three quarters to one full turn open, that is, anti-clockwise from the fully closed position.
3. The Main Adjusting Needle (Item 11 on page 19) should be set to give maximum power under working conditions. It is usually one and a half turns open.

CHAIN ADJUSTMENT

Remove chain case on left hand side of mower to reveal chain.
After adjusting the cutting cylinder, it is necessary to ensure that the chain is loose enough to work properly, without being too loose.
It should be possible to move the slack part of the chain about half an inch (13mm.) altogether.
Chain tension is controlled by a nylon slipper mounted on an adjustable bracket, which is fixed to the mower sideplate by a screw and nut.
Loosen the nut, then move the nylon slipper to the left to loosen the chain, or to the right to tighten the chain, as required.
Tighten the nut again before starting the engine.

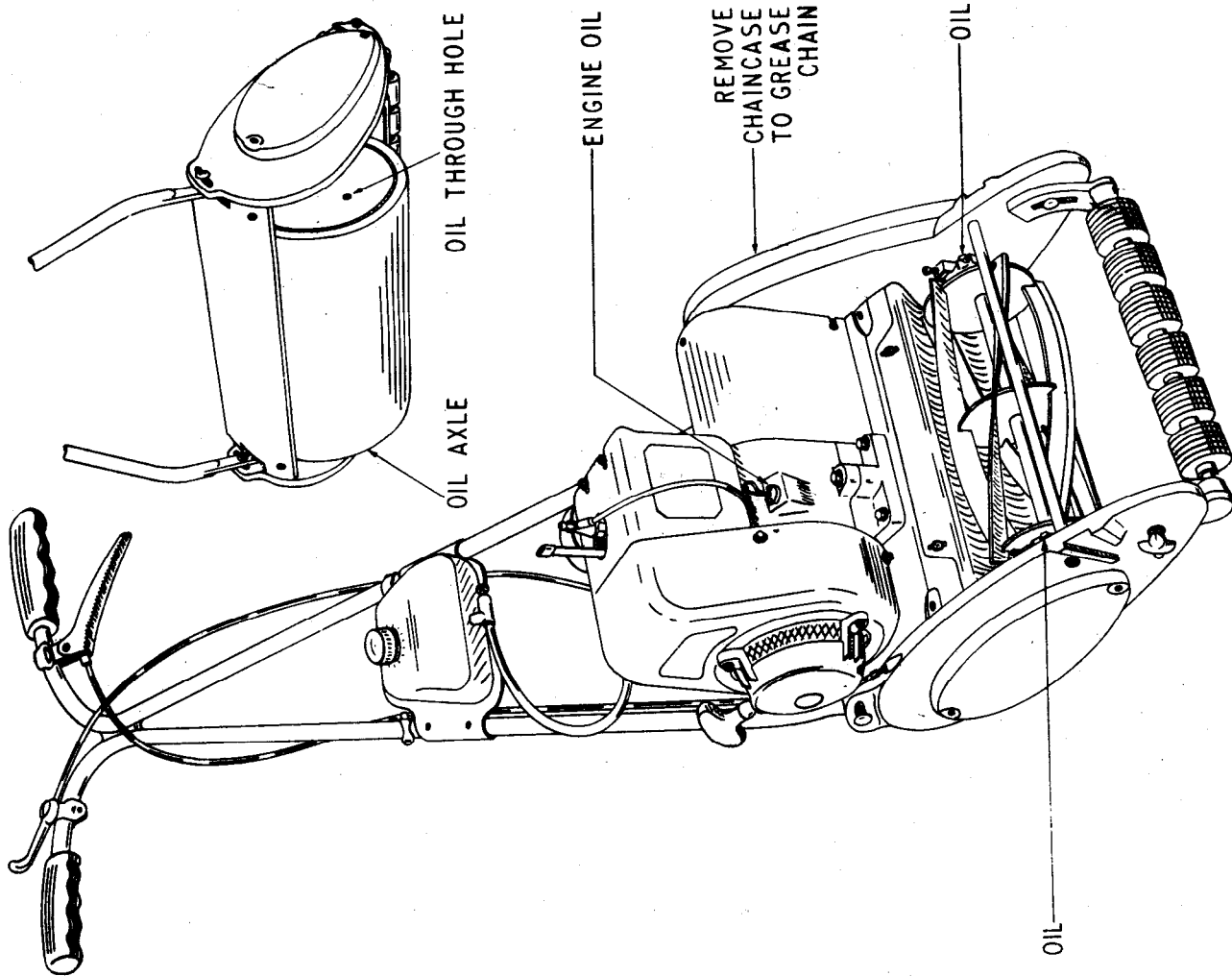

Fig. 7

MOTOR MOWER SPARE PARTS LIST

Ref. No.	Description	Part No.	No. per set	Ref. No.	Description	Part No.	No. per set
1	Grassbox ...	L. 8508	1	51	Mills Pin for Lever Arm	L. 8414	1
2	Sideplate R.H.	L. 8443	1	52	Lever Arm and Spindle	L. 9039	1
3	Sideplate L.H.	L. 8444	1	53	Mills Pin for Belt	L. 8415	1
4	Tie Rod ...	L. 8446	1	54	Mills Pin for Clutch Shoe	L. 8810	2
5	Delivery Plate	L. 8447	1	56	Removable Ratchet Plate for Clutch	L. 8416	2
6	Engine Platform	L. 8449	1	57	Removable Ratchet Plate for Lever Arm	L. 8417	1
7	Nuts for Tie Rod	IN32A	2	58	Cable for Jockey Pulley	L. 8489	1
8	Spring Washer for Tie Rod & Roller Brackets	IN624	4	59	Belt Guide ...	L. 8490	1
9	Roller Bracket, R.H.	L. 5198	1	60	Belt Cover ...	L. 8491	1
10	Roller Bracket, L.H.	L. 5199	1	61	Screw for Belt Cover	L. 8798	2
11	Bolt for Roller Bracket	L. 8673	2	62	Woodruff Key for Clutch Backplate	L. 3845	1
12	Nut for Handle	3N45A	2	63	Clutch Spring	L. 8712	2
13	Bottom Blade Unit ...	L. 8779	1	65	Clutch Backplate	L. 8711	1
14	Bolt for Bottom Blade Unit	1A137S	2	66	Flanged Bush for	L. 6162	1
15	Bearing Block, R.H.	L. 8536	1	67	Clutch Backplate	L. 7034	2
16	Bearing Block, L.H.	L. 8537	1	68	Plain Bush for Rear Roller	L. 8708	2
17	Ball Retainer	L. 2968	2	69	Clutch Shoe	L. 8708	2
18	Cup for Ball Retainer	L. 2969	2	70	Clutch Spindle & Drum	L. 8496	1
19	Dust Seal ...	L. 6901	2	71	Chain Case	L. 8492	1
20	Cone, Long, L.H. complete with 19	L. 7153	1	72	Thrust Collar for Clutch Spindle	L. 8499	1
21	Cone, Short, R.H. complete with 19	L. 7154	1	73	Thrust Collar for Sprocket	L. 8500	1
22	Spring Washer for Cutting Cylinder	L. 2970	1	74	Spherical Bush	L. 8501	1
23	Spring for Bearing Block	L. 3494	2	75	Bearing Retainer	L. 8502	1
24	Lubricators	L. 6751	2	76	Felt Packing Strip	L. 8503	1
25	Cutting Cylinder, with Cones & Dust Seals	L. 8469	1	77	Screw for Bearing Retainer & Belt Guide	3D270A	4
26	Mills Pin for Cutting Cylinder	L. 6776	1	78	Plug Button	L. 7233	1
27	Adjusting Screw for Bearing Block	L. 7222	2	79	7 Tooth Sprocket	L. 7859	1
28	Nut for Bearing Block Adjusting Screw	L. 6954	2	80	Nut for Clutch Spindle	L. 8388	1
29	Front Roller Spindle	L. 8448	1	81	Sprocket Chain	L. 5148	1
30	Front Roller, Double	L. 8833	3	82	19 Tooth Sprocket	L. 8538	1
32	Rear Roller, complete with bushes	L. 8773	1	83	Chain Adjuster	L. 7062	1
33	Rear Roller Spindle	L. 8450	1	84	Nylon Slipper for Chain Adjuster	L. 7063	1
34	Thrust Washer for Rear Roller	L. 8451	1	85	Screw for Chain Adjuster	ID049S	1
35	Cover Plate for Rear Roller	L. 8775	1	86	Nut for Chain Adjuster	L. 8406	3
36	Nut for Rear Roller Spindle	IN85A	2	87	Washer for Chain Adjuster & Handle	3N561A	1
37	Spring Washer for Rear Roller Spindle	IN625	2	88	Setscrew for Clutch Backplate	L. 3846	1
38	Pinion & Shaft Sub Assembly	L. 8646	1	89	Screw for Chain Case	L. 8583	1
39	Felt Pad for Cylinder Spindle	L. 8472	2	90	Clutch Cover	L. 8516	3
40	Cylinder Pulley Half	L. 8473	2	91	Screw for Clutch Cover	L. 8587	3
41	Cylinder Pulley Spacer	L. 8474	2	92	Soleplate Block	L. 8765	2
42	Rear Roller Pulley	L. 9227	1	93	Nut Grip for Engine Mounting	L. 8770	4
43	Vee Belt	L. 8476	1	94	Nut Grip for Delivery Plate	L. 6961	2
44	Bush for Pinion Shaft	L. 8477	2	95	Washer for Bottom Blade, Delivery Plate & Belt Guide	L. 7132/P	5
45	Nut for Cylinder Spindle & Pinion Shaft	L. 6957	3	96	Finger Wheel	L. 7926	2
46	Torsion Spring	L. 9037	1	97	Clutch Lever	L. 8517	1
47	Jockey Pulley	L. 8815	1	98	Circlip for Jockey Pulley	L. 8585	1
48	Bearing for Jockey Pulley	L. 9056	1	99	Screw for Delivery Plate	L. 8591	2
49	Tension Spring	L. 8487	1	101	Screw for Engine Platform	L. 8592	6
50	Shackle	L. 8488	1	102	Nut for Bottom Blade Unit	IN31A	2
					Screw for Engine Mounting	3D086A	4

Continued on Page 12

Mower Assembly Illustration

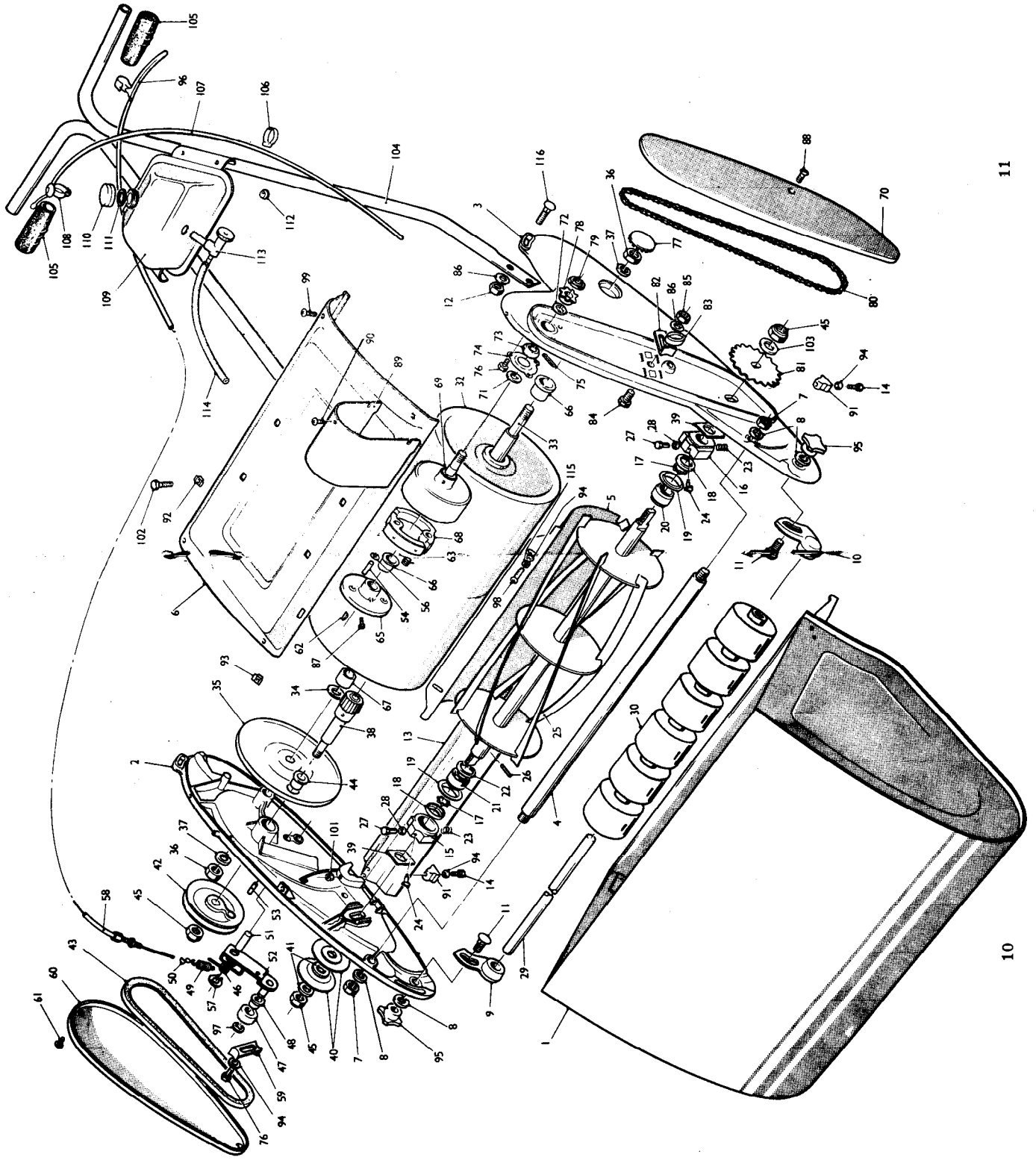

ENGINE SPARE PARTS I.JST.
MODEL 75 G 14. - 25A

Ref. No.	Description	Part No.	No. per set
103	Washer for 19 Tooth Sprocket	IN564A	1
104	Tubular Handle, with Grips	L. 8550	1
105	Handle Grip	L. 8665	2
106	Cable Clip	E. 5315	2
107	Throttle Cable	E. 8934	1
108	Throttle Control Lever	E. 7005	1
109	Petrol Tank, with Cap and Washer	L. 9295	1
110	Screw Cap	E. 9290	1
111	Washer for Cap	E. 9291	1
112	Grommet for Tank	L. 8515	4
113	Petrol Tap	E. 8382	1
114	Petrol Tube	L. 8548	1
115	Spring Washer for Delivery Plate	3N623	2
116	Bolt for Handle	L. 8671/P	2
117	Shim Washer for Rear Roller (not illustrated)	L. 9707	1
118	Washer for Rear Roller Pulley (not illustrated)	L. 9237	2

The above list to be read in conjunction with
MOWER ASSEMBLY ILLUSTRATION
on pages 10 and 11

INSTRUCTIONS FOR ORDERING SPARE PARTS

It is essential to quote the following:

- (a) The Model Name of the machine.
- (b) The engine serial number (See engine assembly illustration)
- (c) The PART NUMBER of the part NOT the illustration number.

Ref. No.	Description	Part No.	No. per set
1	Cylinder Head	E. 7257	1
2	Washer for Cylinder Head	3N561A	8
3	Set-Screws for Cylinder Head	5D336S	4
4	Cylinder Head Gasket	E. 7280	1
5	Cut-out switch	E. 3969	1
5a	Rubber Tube for Cut-out Switch	E. 4083	1
6	Spark Plug	E. 8400	1
7	Washer for Spark Plug		
8	Piston	E. 3513	1
9	Gudgeon Pin	E. 3517	1
10	Wire Circlips	E. 3518	2
11	Compression Ring	E. 3514	1
12	Scrapper Ring	E. 3515	1
13	Oil Ring	E. 3516	1
14	Cylinder Block	E. 8103	1
15	Valve Seat Insert - Exhaust	E. 3534	1
16	Exhaust Valve Guide	E. 3532	1
17	Inlet Valve Guide	E. 3533	1
18	Inlet Valve and Exhaust Valve	E. 3526	2
19	Valve Spring Cotter Pin	E. 3531	2
20	Inlet Valve Spring	E. 3529	1
21	Exhaust Valve Spring	E. 3528	1
22	Valve Spring Retainer	E. 3968	2
24	Paper Gasket for Flywheel Magneto Backplate	E. 3859	3
25	Camshaft Spindle	E. 6789	1
27	Crankshaft	E. 8142	1
28	Key for Magneto Flywheel	E. 3597	1
29	Washer for Crankshaft	E. 8390	1
30	Nut for Crankshaft (Left Hand Thread)	E. 8043	1
32	Main Bearing	E. 3536	2
33	Oil Seal	E. 3813	2
34	Breather Baffle	E. 3561	1
35	Drive Screw for Breather Baffle	E. 3814	1
36	Tappets	E. 3535	2
37	Camshaft	E. 3510	1
38	Washer for Crankcase Breather	E. 3594	1
39	Breather Body	E. 3555	1
40	Disc Valve	E. 3557	1
41	Breather Cap	E. 3556	1
42	Breather Retainer Spring	E. 3558	1
43	Stud for Valve Chest Cover	E. 7098	1
44	Baffle for Valve Chest Cover	E. 3560	1
45	Gasket for Valve Chest Cover	E. 3549	1
46	Cover for Valve Chest	E. 3543	1
47	Washer for Stud	E. 7132	1
48	Nut for Stud	1N44A	1
49	Connecting Rod		
50	Big End Bearing Cap (with ref. No's. 52 & 53)	E. 3519	1
51	Oil Splasher	E. 6426	1
52	Locking Strip	E. 3523	1
53	Screws for Big End Bearing Cap	1D585S	2
54	Paper Gasket for Sump	E. 3547	1
56	Washer for Bolt - Asbestos	E. 3749	1

Continued on Page 16

Engine Assembly Illustration

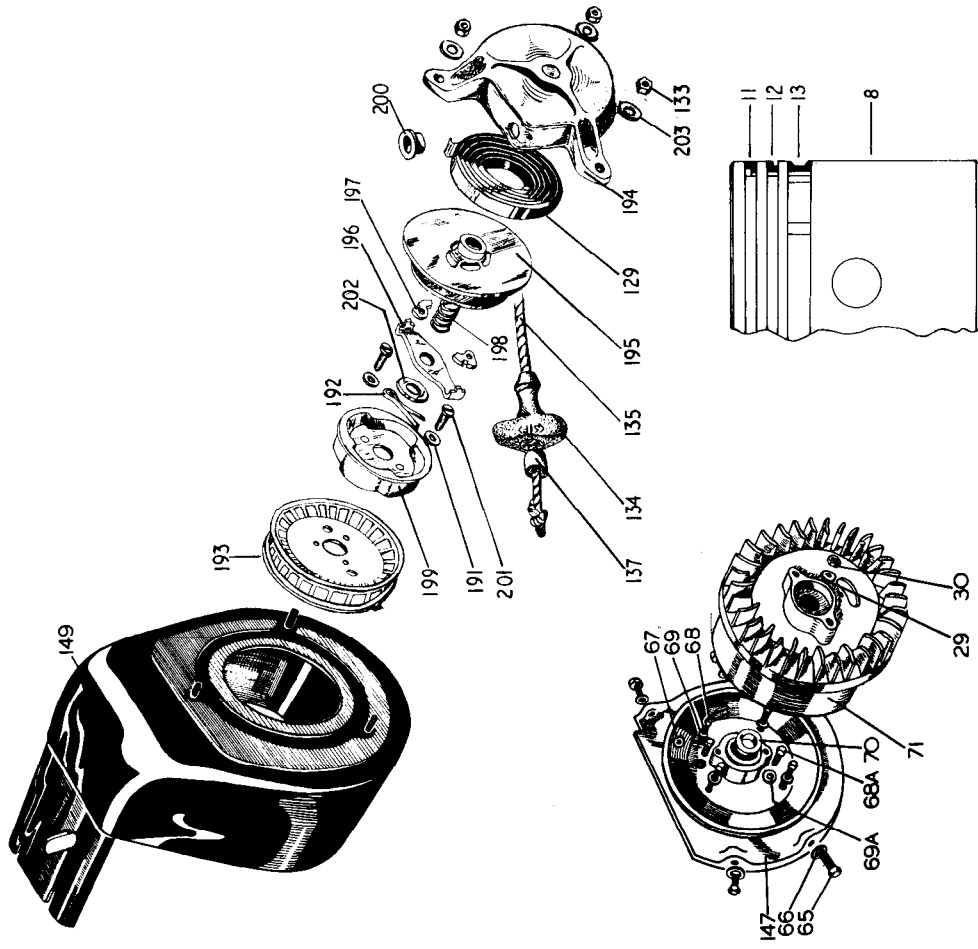
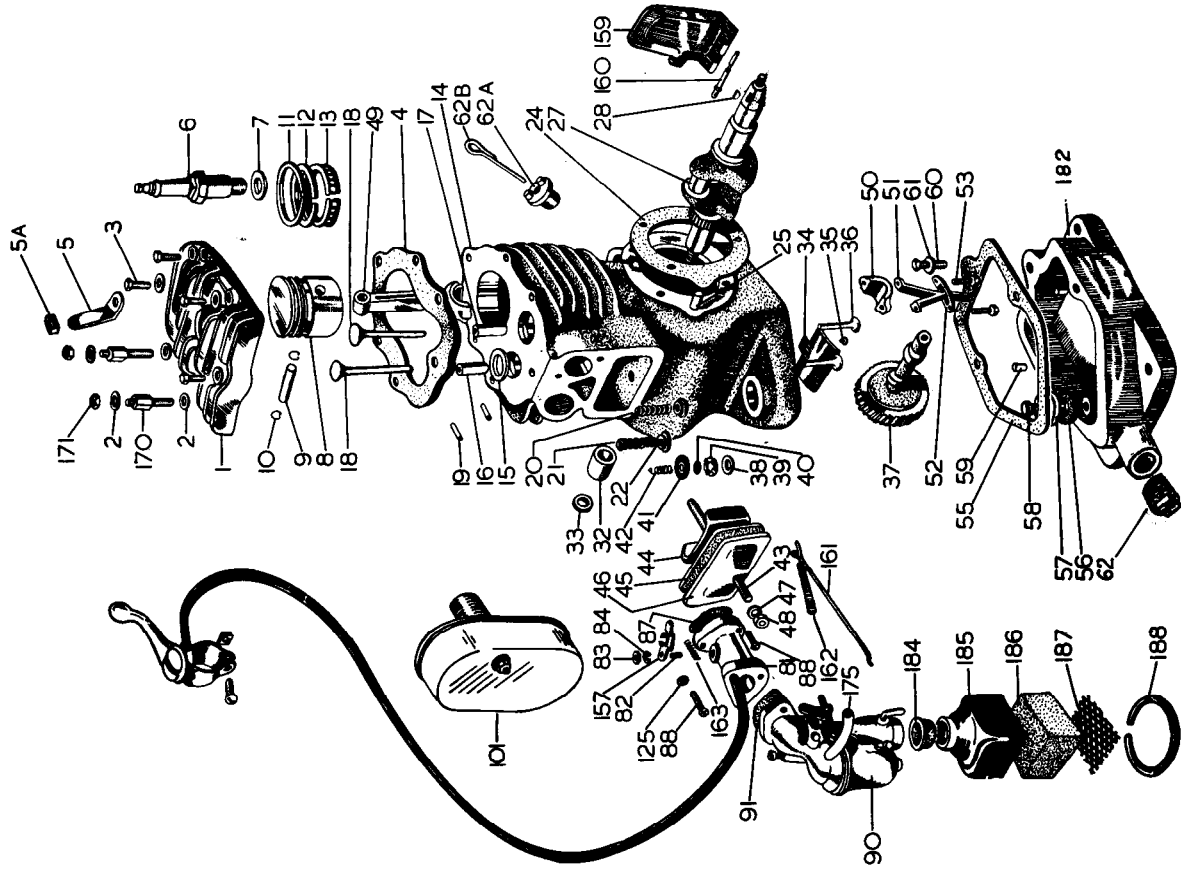

Ref. No.	Description	Part No.	No. Per set
57	Collar for Bolt	E.3566	1
58	Bolt for Sump	1A139A	1
59	Dowels for Sump	E.3819	2
60	Setscrew for Sump	1D087A	1
61	Shakeproof Washer for Setscrew	E.3821	1
62	Drain Plug	E.3822	1
62A	Filler Plug (Export only)	E.7506	1
62A	Filler Plug (Home Trade only)	E.6894	1
62B	Dipstick for Filler Plug	E.6895	1
65	Screw for Cowl	3D270A	4
66	Washer for Cowl	E.7132/P	4
67	Sleeve for H.T. Lead	E.8454	1
68	Screw for Flywheel Magneto Backplate	3D048A	4
68a	Screw for Magneto Stator Plate	3D048A	2
69	Spring Washer for Flywheel Magneto Backplate	3N623	4
69a	Washer for Screw for Magneto Stator Plate	E.7132/P	2
70	Cam Sleeve	E.8146	1
71	Flywheel	E.9300	1
81	Inlet Manifold	E.7437	1
82	Stud for Throttle Lever	E.8017	1
83	Nut for Throttle Lever	E.8015	1
84	Washer for Throttle Lever	3N610A	1
87	Gasket for Inlet Manifold	E.8589	1
88	Screw for Carburettor & Inlet Manifold	E.9087	4
90	Carburettor	E.7179	1
91	Gasket for Carburettor	E.8640	1
101	Exhaust Silencer	E.8685	1
125	Spring Washer for Inlet Manifold and Carburettor Assembly	3N623	4
129	Recoil Spring	E.5516	1
133	Nuts for Cover	4N31A	3
134	Rubber Handle	E.5518	1
135	Nylon Rope	E.5517	1
137	Ferrule for Rubber Handle	E.9035	1
147	Magneto Backplate, complete with Ref. 32	E.8169	1
149	Cowl	E.8241	1
157	Throttle Lever	E.7161	1
159	Governor Blade	E.8202	1
160	Governor Blade Spindle	E.8336	1
161	Throttle Link	E.8204	1
162	Governor Spring	E.8203	1
163	Throttle Return Spring	E.6531	1
170	Studs for Cylinder Head	E.8170	2
171	Nuts for Cylinder Head Studs	3N45A	2
182	Sump	E.6889	1
184	Rubber Bush for Air Filter	E.7174	1
185	Air Filter Body	E.7173	1
186	Air Filter Element (Foam)	E.8593	1
187	Air Filter Screen	E.7175	1
188	Wire Circlip for Air Filter	E.3579	1
189	Air Filter Assembly, comprising Ref. No's. 184 to 188, inc.	E.7176	1
191	Shakeproof Washer for 201	L.3844/B	2
192	Split Pin for Starter Cover	L.3847	1
193	Rotary Screen	E.9255	1
194	Cover for Starter, inc. Ref. 200	E.9327	1
195	Pulley for Starter	E.9328	1
196	Activator for Starter	E.9329	1

The above list to be read in conjunction with
ENGINE ASSEMBLY ILLUSTRATION.
on pages 14 and 15.

Ref. No.	Description	Part No.	No. Per set
197	Pawl	E.9330	2
198	Compression Spring	E.9331	1
199	Driving Hub	E.9332	1
200	Eyelet for Cover	E.9333	1
201	Screw for Driving Hub	4K298A	2
202	Washer for Cover, 5/16"	4N561A	1
203	Washer for Cover, 1/4"	E.7132/P	3

SPARE PARTS LIST FOR ZENITH CARBURETTER

TYPE 13.TCA - 2.

Carburettor Illustration

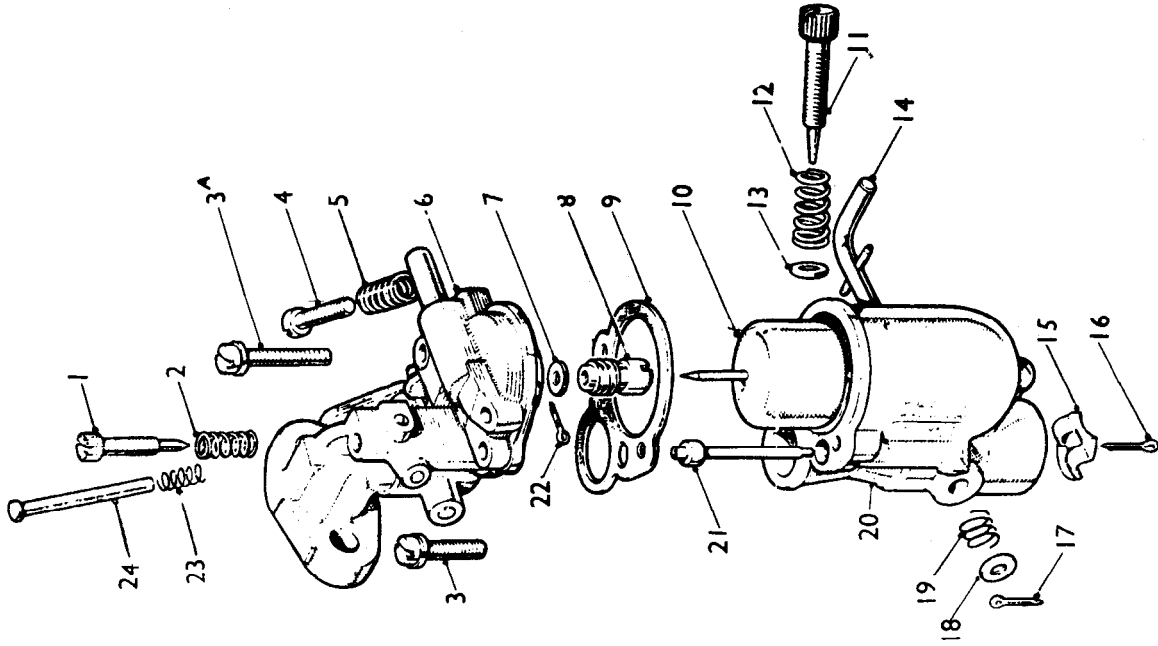

Ref. No.	Description	Part No.
1	Air Regulating Screw	015457
2	Spring for Ref. 1	015458
3	Screw and Spring Washer fixing Bowl to Barrel (Short)	020584
3a	Screw and Spring Washer fixing Bowl to Barrel (Long)	019651
4	Throttle Stop Screw	015547
5	Spring for Ref. No. 4	08539
6	Carburettor Barrel Assembly	020573
7	Washer for Needle Seating	020574
8	Needle Seating	08523
9	Gasket (Bowl to Barrel)	020583
10	Float and Needle Assembly	020507
11	Adjustment Needle	020576
12	Spring for Ref. No. 11	09846
13	Fibre Washer for Ref. No. 11	16709
14	Strangler Spindle and Pin Assembly	020579
15	Strangler Flap	013635
16	Split Pin for Ref. No. 15	05370
17	Split Pin for Spindle	05370
18	Washer for Spindle	08860
19	Friction Spring	013650
20	Carburettor Bowl	020575
21	Slow Running Tube	020582
22	Split Pin for Tickler Stem	05890
23	Tickler Spring	015454
24	Tickler Stem	020572

This list to be read in conjunction with

EXPLODED ILLUSTRATION OF CARBURETTER on Page 19

MAGNETO SPARE PARTS LIST

Ref. No.	Description	Part No.	No. Per set
1	Flywheel Assy., inc. Ref. No. 3	E.9300	1
3	Inspection Cover	E.9304	1
6	Stator Unit S/A, Items 7-18 inc.	E.8108	1
7	Stator Plate Assembl (not supplied separately)	E.8115	1
8	Coil & Condenser Assembly	E.8123	1
9	Retaining Clip for Coil	E.8126	1
10	Lead Clamp Screw	E.8149	1
11	Star Washer for Clamp Screw	E.8160	1
12	Cam Wiper Felt	E.5047	1
13	Adjuster Plate Assembly	E.8524	1
14	Breaker Arm Assembly	6N611A	1
15	Retaining Clip for Breaker Arm	E.8131	1
16	Washer for Adjuster Plate Screw	E.5042	1
17	Screw for Adjuster Plate	E.5052	1
18	Star Washer for Adjuster Plate	E.8146	1
19	Wave Washer	E.8124	1
20	Cam Sleeve	E.8454	1
21	H.T. Lead	E.8124	1
22	Sleeve for H.T. Lead	E.8454	1
23	Suppressor	E.7858	1

The above list to be read in conjunction with

MAGNETO ASSEMBLY ILLUSTRATION on Page 20

Magneto Assembly Illustration

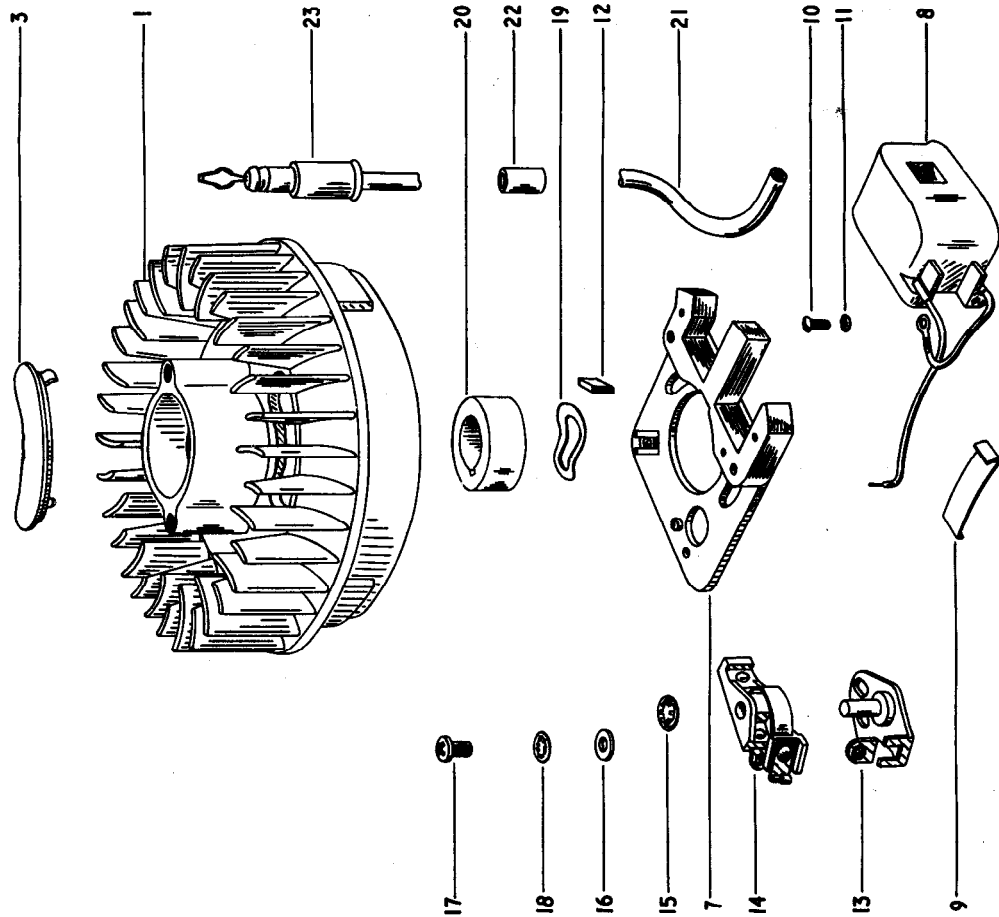

SPARES AND SERVICE

We have Service Branches covering the whole of the United Kingdom and in addition some 400 appointed agents in all principal towns to give "on the spot" service to all our machines.

In the event of spares or service being required, therefore, please contact your nearest branch or write to Suffolk Lawn Mowers Ltd., Sunnyhill Avenue, Derby. DE3 7LL for the name and address of your nearest appointed service agent.

ATCO SERVICE BRANCHES

DARLINGTON (Co. Durham)
McMullen Road,
Darlington DL1 1XZ
Telephone: 0325-2671, 66939

SCOTLAND
Industrial Estate,
Larkhall, Lanarkshire ML9 2PF
Telephone: 0698-882370

SHEFFIELD (Yorks)
Rotherham Road,
Eckington S31 9FH
Telephone: 024683-2373/4

NORTHERN IRELAND
Rugby Engineering Works,
101 Rugby Avenue,
Belfast BT7 1RF
Telephone: Belfast 27147
& 26762

PRESTON (Lancs)
School Lane,
Longton, Preston PR4 4SA
Telephone: 0772-612451/2

BIRMINGHAM (Warks)
P.O. Box No. 256,
Tilton Road, Small Heath,
Birmingham B9 4PR
Telephone: 021-773 1441/3

NEWMARKET (Suffolk)
176 Exning Road,
Newmarket CB8 0AG
Telephone: 0638-4418/9

CHEPSTOW (Mon.)
Castleford, Tutshill,
Chepstow NP6 7YJ
Telephone: 02912-2732, 2114

READING (Berks)
7-9 Boulton Road,
Reading RG2 0ND
Telephone: 0734-84258/9

EXETER (Devon)
14 Marsh Green Road,
Marsh Barton, Exeter EX2 8PG
Telephone: 0392-73882,
54017

LONDON (Surrey)
61 Albert Road North,
Reigate RH2 9EP
Telephone: 0732-45731/5

